

FSP-D40 ▶▶



Solar DC Surge Protective Device (DC SPD)

CCC CE  RoHS

Modular Type
Easy To Be Replaced

Integrated Molding Base

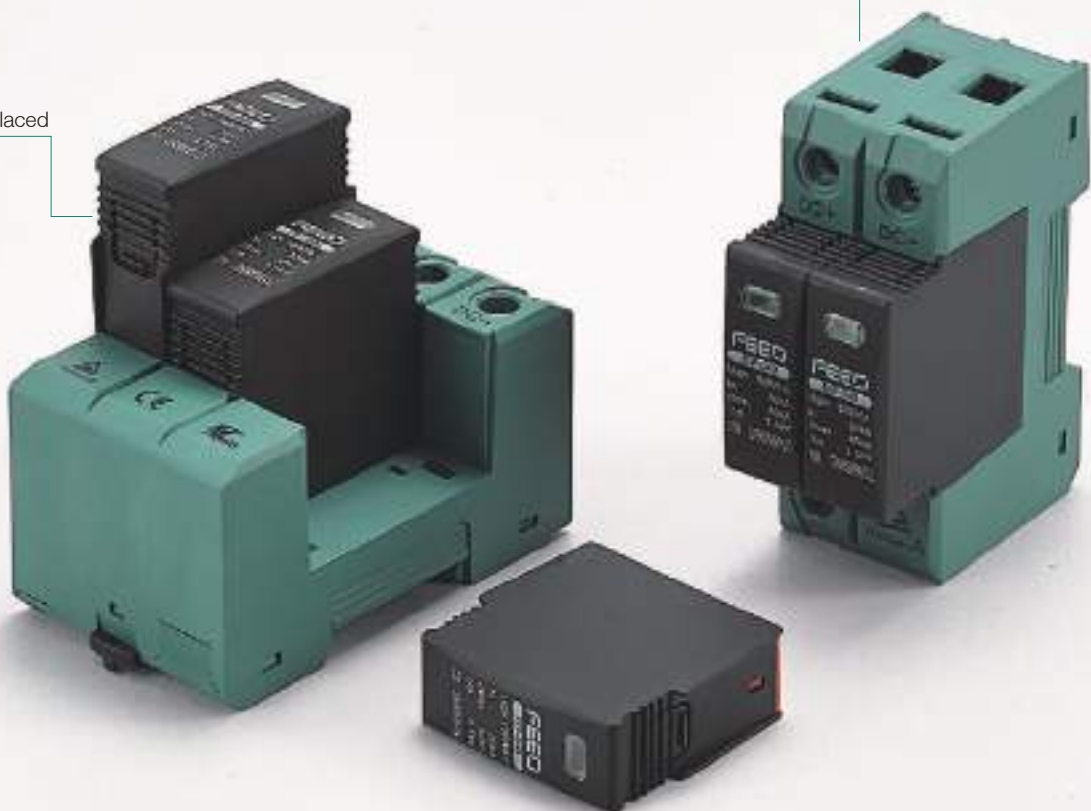

Type2 Solar DC Surge Protective Device (DC SPD)

► Application

Surge protective device, protect against lightning surge voltages in solar system (photovoltaic power supply system). These units must be installed in parallel on the dc networks to be protected and provide common and different modes protection. Its installed location are recommended at both ends of the dc power supply line (solar panel side and inverter/converter side), especially if the line routing is external and long. High energy MOVs equipped with specific thermal disconnectors and related failure indicators.



► Specifications

FSP-D40 Surge protector	FSP-D40				
PVDC - specific	EN50539-11				
Pole	2P	2P	3P	3P	2P(CUSTOMIZED)
Electrical parameter					
Classified test	II	II	II	II	II
Uoc max (VDC)	600	800	1000	1500	12/24
Uc (VDC)	600	800	1000	1500	12/24
In (8 /20)us (kA)	20	20	20	20	20
I _{ma} x (8 /20)us (kA)	40	40	40	40	40
Up (kV)	2.0	2.5	3.8	5.3	2.0

► Remote Signal Contact

Remote signal contact	Maximum working voltage (V)	250VAC/30VDC	250VAC /30VDC
	Maximum working current (A) IA (250 V /AC)	IA (250V/AC)	IA (250V /AC)
	IA (30 V DC)	IA (30V/AC)	IA (30V /AC)

► Installation and Dimensions

Wiring capacity(mm ²)	Hard wire	4~25	4~25
	Flexible wire	4~16	4~16
Stripping length(mm)		10	10
Terminals crwca		M5	M5
Torque (Nm)	Main circuit	3.5	3.5
	Remote signal contact	0.25	0.25
Protection class	All profile	IP40	IP40
	Connection port	IP20	IP20
Installation environment		No obvious shock and vibration	
Altitude (m)		≤2000	≤2000
Working Temperature		-30℃ ~ +70℃	-30℃ ~ +70℃
Relative humidity		30%~90 %	30%~90 %
How to install		Installed with H 35-7.5/DIN35 steel mounting rail	
Size (mm) (W x H x L)	W	36	54
	H	90	90
	L	67.6	67.6
Weight (kg)		0.24	0.36

FSP-D40

YUEQING FEEO
ELECTRIC CO.,LTD

Type2 Solar DC Surge Protective Device (DC SPD)

► Wiring Diagram

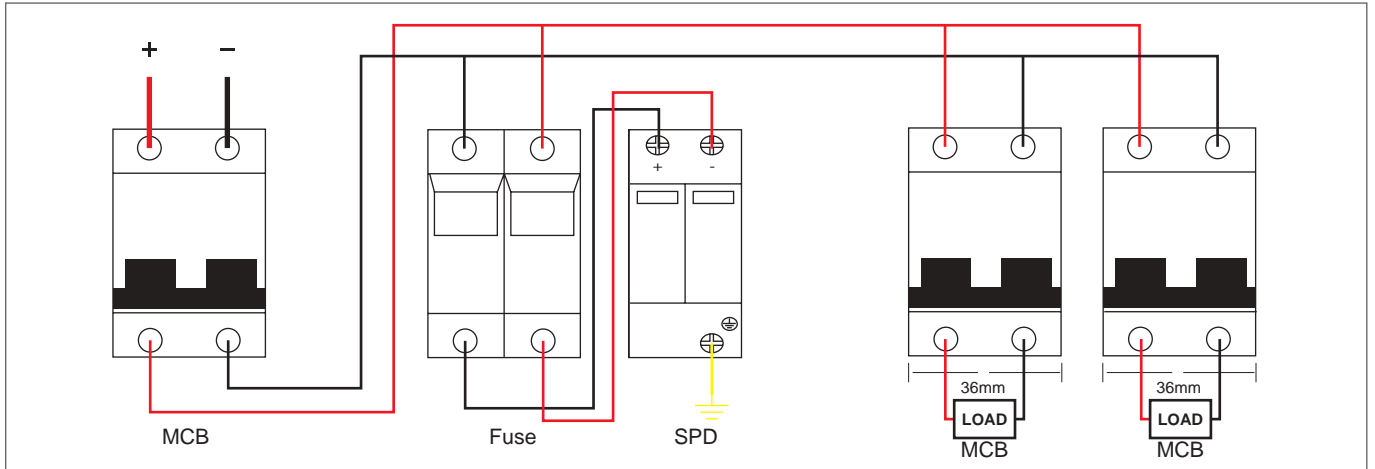

► Dimensions

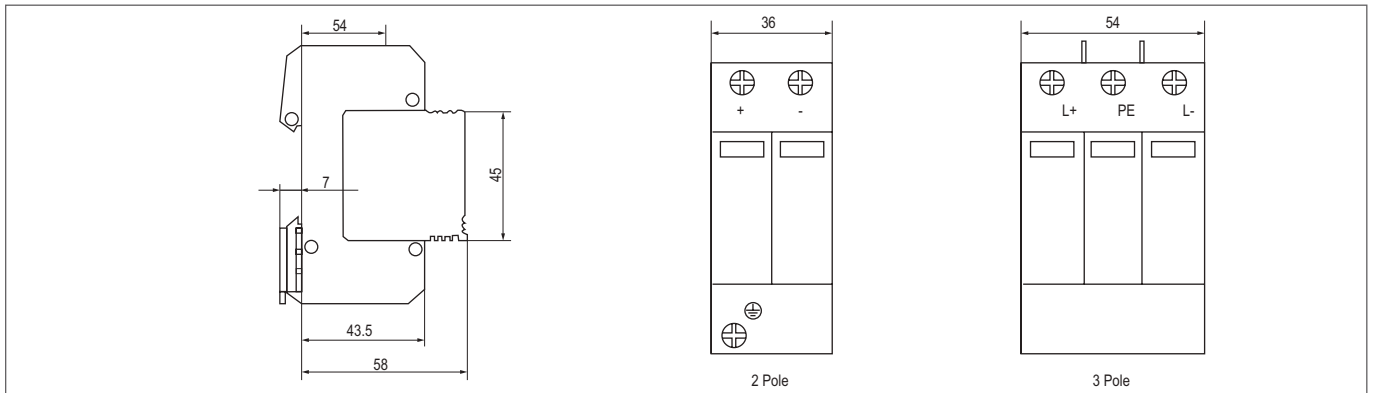

► Drawing

